

SPECIFICATION

FLUID	: Air or neutral gas, filtered, lubricated
PRESSURE	: 2,5 to 10 bar
TEMPERATURE	: +10°C to +40°C
FLOW (Qv at 6 bar)	: 406 l/min (SRA)
Ø NOMINAL	: 4 mm
PORTS	: G 1/8
FUNCTION	: 3/2 NC - 3/2 NO
LIFE	: 10 million cycles
CONFORMING to CNOMO standard 06-05-25	

CONSTRUCTION

Pilot operated spool valve features:

- **snap-action** operation
- low actuating force

Body: light alloy

Internal parts: stainless steel and light alloy

Sealings: NBR (nitrile)

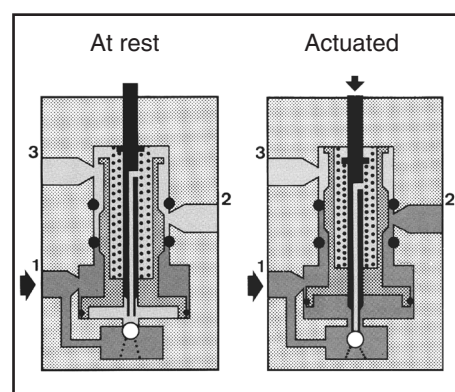

CHOICE OF EQUIPMENT

OPERATING HEADS			CODES		
			HEAD ALONE	COMPLETE PILOT VALVE	
				NC function 	NO function
Type	Designation	Mechanical actuation			
	Pilot valve without operating head		-	32000001	32000002
	Pilot valve with mounting screws		-	32000065	32000066
	Single lever	Right and left	88132001	32000039	32000052
		Right or left	88132002	32000040	32000053
	Adjustable lever	Right and left	88132019	32000041	32000054
		Right or left	88132020	32000042	32000055
	Flexible rod lever	Right and left	88132021	32000043	32000056
		Right or left	88132029	32000044	32000057
	Forked one-track roller	Maintained position	88132022	32000045	32000058
	Top roller plunger	Operating force 1,3 daN	88132023	32000046	32000059
	Horizontal side roller plunger	Operating force 2,6 daN	88132024	32000047	32000060

00412GB-2017/R01
Availability, design and specifications are subject to change without notice. All rights reserved.

DIMENSIONS AND WEIGHTS

Pilot valve without operating head
Weight: 0,265 kg

Pilot valve with 4 CM4 screws, 33 long,
for on-site assembly of operating head

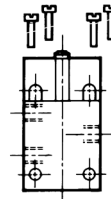
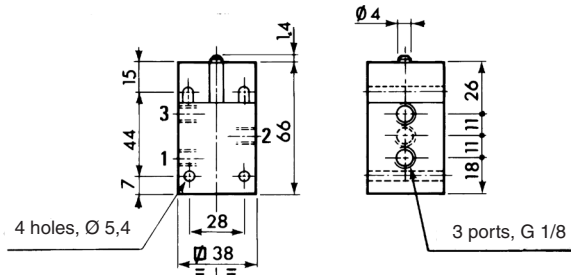

Single lever
Weight: 0,505 kg

Adjustable lever
Weight: 0,515 kg

Flexible rod lever
Weight: 0,505 kg

Forked one-track roller
Weight: 0,530 kg

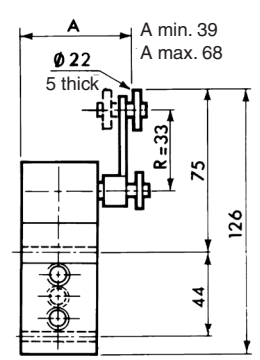
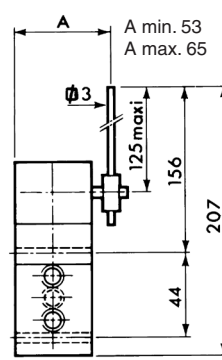
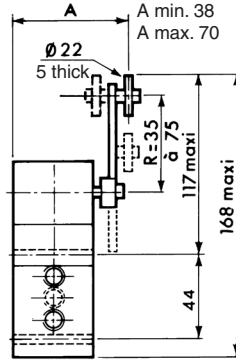
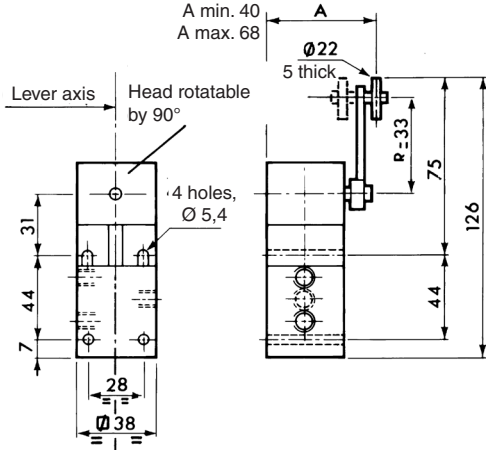

Top roller plunger
Weight: 0,465 kg

Horizontal side roller plunger
Weight: 0,510 kg

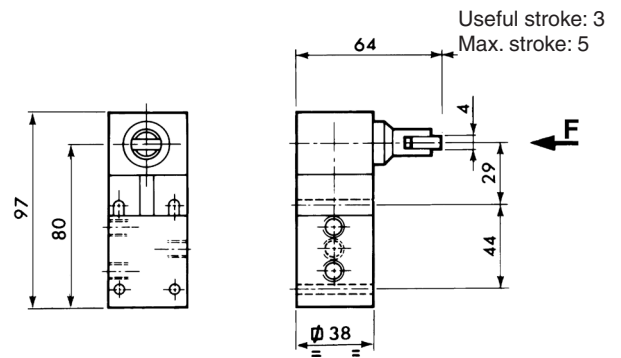
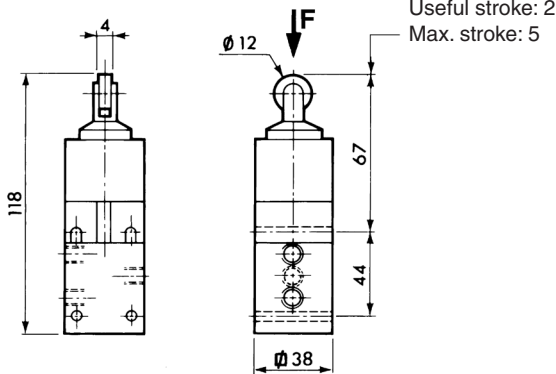

ASSEMBLY

● SINGLE, ADJUSTABLE OR FLEXIBLE LEVER HEADS RIGHT OR LEFT ACTUATION

Actuation speed (v)	Cam angle (α_1)	Lever position (α_2)*
$\leq 1,5$ m/s	30° max.	$0 < \alpha_2 < 35^\circ$
$1,5 < v < 5$ m/s	10° max.	$0 < \alpha_2 < 55^\circ$

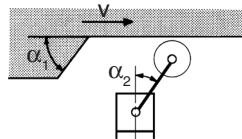

RIGHT AND LEFT ACTUATION

Actuation speed (v)	α_1 and α_3
$\leq 1,5$ m/s	max. 30°
$1,5 < v < 5$ m/s	max. 10°

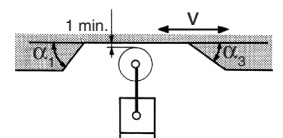

Max. travel: 75° from rest position.

* A pre-travel** of 25° must be added to the positioning ranges 0° to 35° and 0° to 55°.

Max. travel: 75° on either side of the rest position.

Pre-travel**: 25° on either side of the rest position.

** The pre-travel is the minimum angular distance that the lever must be moved by the mobile element or the cam (from the rest position) to assure the valve's function.

● FORKED ONE-TRACK ROLLER, MAINTAINED POSITION

Actuation speed (v)	Cam angle (α_1)
$\leq 0,5$ m/s	$45^\circ < \alpha_1 < 90^\circ$

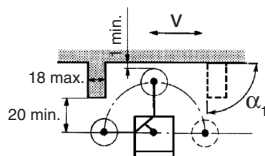

● ROLLER HEADS

These completely interchangeable heads can take 4 positions at 90° to the vertical axis of the device. The direction of actuation is indicated by the arrow F (actuation speed: 0,25 m/s).