

SPECIFICATIONS

FLUID	: Air or neutral gas, filtered, lubricated or not
PORTS	: instant fittings Ø4 O.D. or G 1/8
PRESSURE	: 0 to 10 bar
TEMPERATURE	: -5°C to +60°C
FLOW (Qv at 6 bar)	: 280 l/min (ANR)
Ø NOMINAL	: 3,5 mm

CONSTRUCTION

Spool and poppet design closed centre
 Body zinc diecasting
 Internal parts acetal
 Sealing NBR (nitrile)



CHOICE OF EQUIPMENT

FUNCTION NC Normally closed		 1 = Pressure 2 = Outlet 3 = Exhaust		CODES	
Type	Description	Operating effort (daN)	Head ALONE	COMPLETE PILOT VALVE	
				Instant fittings	G 1/8
—	Valve alone BODY NC	5	—	31090002	31090001
	Push button Ø 40	5	88131007	31000015	31000008
	Impulse mushroom Ø 60	5	88131004	31000016	31000009
	Lever positive 2 maintained positions	—	88131003	31000017	31000010

DIMENSIONS AND WEIGHTS

Valve alone
Weight : 0,100 kg

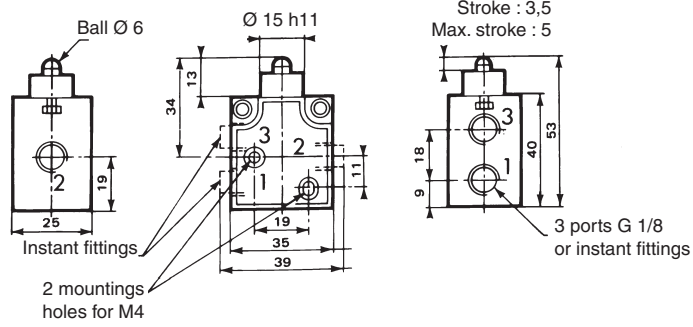

Button Ø 40
Weight : 0,145 kg

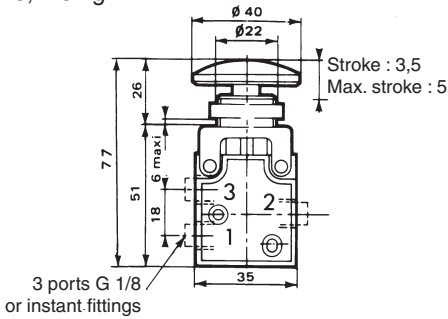

Impulse mushroom Ø 60
Weight : 0,150 kg

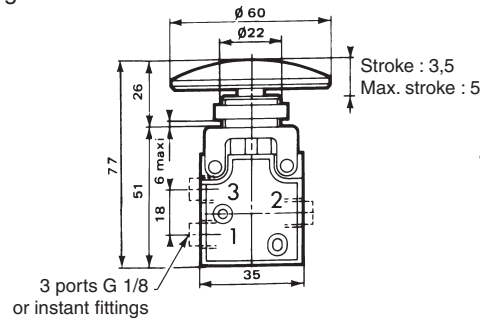

Lever positive, 2 maintained positions
Weight : 0,120 kg

