

### SPECIFICATIONS

FLUID	: Air or neutral gas, filtered, lubricated
PRESSURE	: 0 to 10 bar
TEMPERATURE	: -10 °C to +60 °C
FUNCTIONS	: 3/2 - 5/2
PORTS	: G 1/8
FLOW (Qv at 6 bar)	: 200 l/min (ANR)

### CONSTRUCTION

Body anodized light alloy  
Covers light alloy and acetal  
Internal parts light alloy  
Sealing nitrile (NBR)  
Button synthetic resin  
Possible mounting panel (percing Ø 16,5)  
The 3/2 spool valve can be used as a 3/2 NC or 3/2 NO version, by connecting as indicated opposite



Ports of 3/2	
<b>NC</b>	<b>NO</b>
1 = Pressure	Exhaust
2 = Outlet	Outlet
3 = Exhaust	Pressure

Ports of 5/2	
1 = Pressure	
2,4 = Outlets	
3,5 = Exhausts	

### CHOICE OF EQUIPMENT

	Symbols Functions	Operators		CODES
		Pilot	Return	
<b>3/2</b>		Push button	Spring	<b>55000040</b>
		Push-pull button		<b>55000039</b>
		Lever - lever detented		<b>55000043</b>
<b>5/2</b>		Push button	Spring	<b>55000009</b>
		Push-pull button		<b>55000010</b>
		Lever - lever detented		<b>55000011</b>

**DIMENSIONS AND WEIGHTS**

**3/2**

PUSH BUTTON / SPRING RETURN  
PUSH-PULL BUTTON

Weight : 74 g

**5/2**

Weight : 94 g

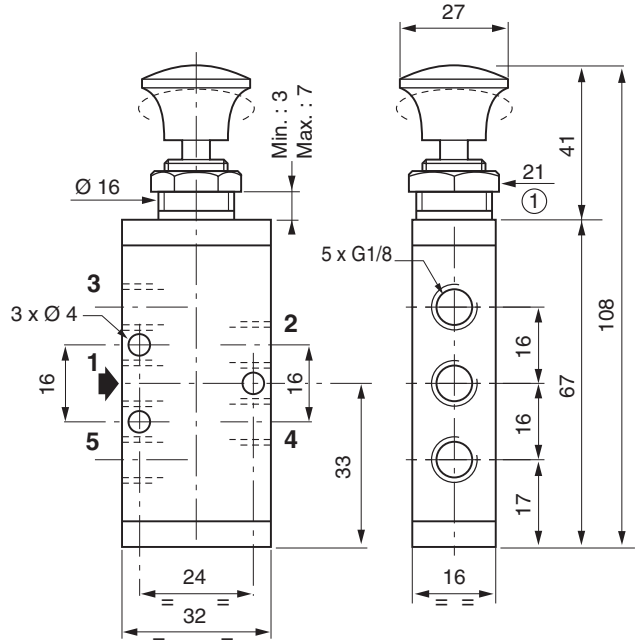
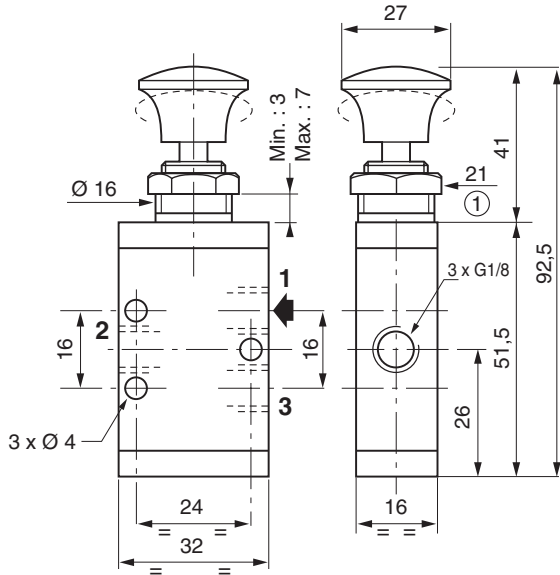

LEVER - LEVER DETENTED

Weight : 76 g

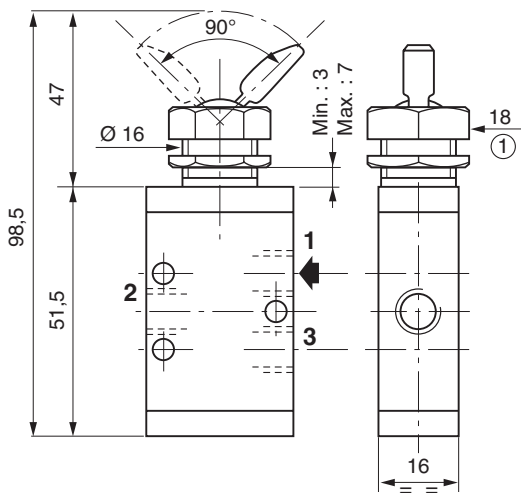

Weight : 92 g

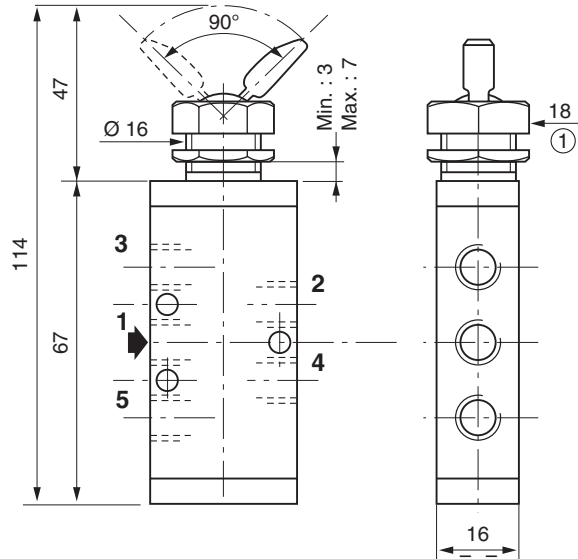

① Dimensions on flats